

Important notes on VOSS assembly instructions

In order to ensure maximum performance and functional reliability of VOSS products, the respective assembly instructions, operating conditions and tube recommendations have to be adhered to.

We recommend that you use VOSS pre-assembly devices at all times. The use of pre-assembly devices is a strict requirement from tube sizes L18/S16 and larger! It is absolutely essential to follow the operating instructions for the respective pre-assembly device used.

Do not start with assembly until you are absolutely sure that you have understood the operating and assembly instructions for each VOSS pre-assembly device or machine, tool and product. Incorrect handling leads to risks regarding safety and leak-tightness and can result in failure of the entire connection.

It is impossible for the manufacturer to monitor whether the user is adhering to the operating and assembly instructions for individual pre-assembly devices or machines, tools and products, as well as what conditions prevail and what methods are used for installation, operation, application and maintenance of the individual products. Improper workmanship can lead to material damage, which in turn may pose a danger to life and limb. This means that VOSS Fluid GmbH can accept no responsibility or liability for loss, damage or costs incurred due to faulty installation, improper operation or incorrect application and maintenance or from any related issue. Failure to heed this warning will lead to loss of guarantee.

VOSS Fluid GmbH reserves the right to make changes or additions to the information provided without prior notification. Customers can obtain the latest version of the operating and assembly instructions upon request, or from our download area at: www.voss.net

General notes on VOSS assembly instructions

Make sure that all components, including the tubes, are clean before assembly is started and that they remain clean during the entire assembly process. Soiled components may lead to failure of the system.

Before starting assembly, make sure that you have carried out all preparatory work in accordance with the respective instructions.

Specifications concerning permissible steel tubes:

seamless, cold-drawn and normalized precision steel tubes as specified in DIN EN 10305-4, material E235+N, mat. no. 1.0308+N or E355, mat. no. 1.0580. The tubes must be ordered by specifying the outer diameter and the inner diameter.

Specifications concerning permissible stainless steel tubes:

seamless, cold-drawn and solution-annealed, scale-free stainless steel tubes in CFA or CFD delivery condition of dimensions and tolerances according to DIN EN 10305-1 and all other delivery conditions as specified in DIN EN 10216-5, material X6CrNiMoTi17-12-2, mat. no. 1.4571. The tubes must be ordered by specifying the outer diameter and the inner diameter.

The tubes should be prepared with the same thoroughness as pre-assembly and final assembly of the connection. Especially when using long tubes, check the end sections for damage or distortion.

We recommend that pre-assembled tubes which are not to be finally assembled yet should be fitted with protective caps.

Marking a stroke on the union nut and the tube makes it easier to achieve the correct number of turns when tightening the coupling.

Before starting to assemble VOSS components with elastomer seals, always check that:

- the nut and the seal surfaces are clean and undamaged and/or
- the elastomer sealing is clean and undamaged

Determining the tightening torque for screw couplings

The tightening torques specified in the catalogue apply under the following conditions:

- steel fittings with VOSS coat surface coating
- the specified nominal pressure ranges assume that the mating material has a tensile strength of $\geq 600 \text{ N/mm}^2$
- our recommendations on lubrication of the threaded studs are observed

If other values for strength, modulus of elasticity and friction-surface combinations are used, the user has to adapt the tightening torque empirically.

The recommended tightening torques have to be adhered to if the pressure range is to be fully utilized and the appropriate safety level is to be maintained.

The recommended tightening torques for the threads are given in the tables for the respective type of thread.

Explanation of symbols and other notes



Visual inspection



Turn until hand-tight or carry out another manual activity



Use the tool to tighten the coupling according to the instructions



Oil and lubricate at the point marked with an arrow

All dimensions in millimetres [mm]

Assembly instructions for ES-4 tube couplings

1

Notes

Before starting the assembly work, read the general notes in the latest VOSS catalogue and check that your assembly instructions are up to date

These assembly instructions describe the possible assembly options provided for in the German standard DIN 3859 Part 2.

We recommend that VOSS pre-assembly devices and tools are used for assembly at all times.

For use with steel tubes in accordance with VOSS specifications (see introduction to assembly instructions).

Attention!

Please note the recommendation on the use of tube supports for thin-walled steel tubes and soft tubes made of non-ferrous metals.

This cutting ring is not suitable for stainless-steel tube assemblies. For these, cutting rings of types VOSSRing^M, 2SVA or ES-4VA must be used!

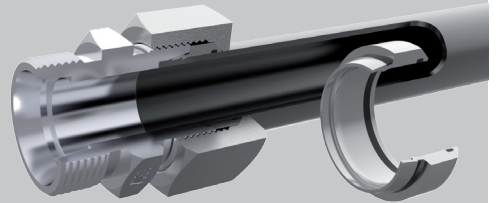

2

Tube preparation

2.1 The minimum dimensions of the straight tube ends must be taken into account for determining the tube lengths.

Series	Tube OD [mm]	H [mm]	L [mm]
L	6/8	31	39
L	10/12	33	42
L	15	36	45
L	18	38	48
L	22/28	42	53
L	35/42	48	60

Series	Tube OD [mm]	H [mm]	L [mm]
S	6/8	35	44
S	10/12	37	47
S	14/16	43	54
S	20	50	63
S	25	54	68
S	30	58	72
S	38	65	82

With machine pre-assembly, the minimum lengths are contained in the respective operating instructions of the pre-assembly devices.

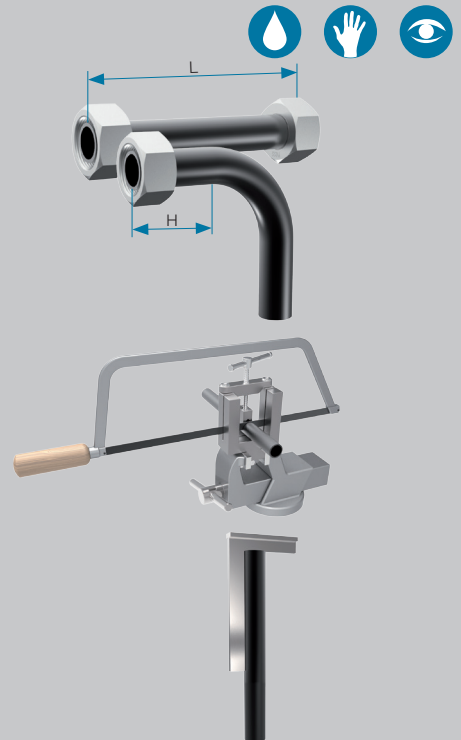

ES-4

2.2 Saw tube off at right angles. An angle tolerance of $\pm 1^\circ$ is permissible. Do not use a rotary grinder or tube cutter.

2.3 Slightly deburr tube ends inside and outside. Clean the tube.

Attention!

If tubes are not cut off squarely or are not properly deburred, this may reduce the service life and leak-tightness of the couplings. Burrs on the tube outer diameter can damage the inner O-ring.

2.4 Assembly of VOSS reinforcing sleeves

1. Lubricate the outside surface of the sleeve lightly (e.g. using mineral-oil based hydraulic fluid HLP32). Then insert the sleeve into the tube up to the knurled section.
2. Use a hammer (plastic or hard rubber) to drive the sleeve in totally. In doing so, the knurled section is pressed against the inner wall of the tube and prevents the sleeve from being displaced or from falling out.

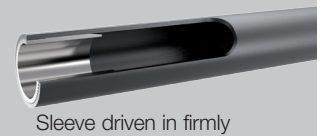
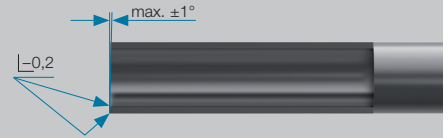

Series	Tube OD [mm]	Wall thickness [mm]						
		0.5	0.75	1	1.5	2	2.5	3
L	6	•	•					
L	8	•	•					
L	10	•	•					
L	12	•	•	•				
L	15	•	•	•				
L	18	•	•	•	•			
L	22	•	•	•	•	•		
L	28	•	•	•	•	•		
L	35	•	•	•	•	•	•	
L	42	•	•	•	•	•	•	
S	6	•	•					
S	8	•	•					
S	10	•	•					
S	12	•	•	•				
S	14	•	•	•				
S	16	•	•	•	•			
S	20	•	•	•	•	•		
S	25	•	•	•	•	•		
S	30	•	•	•	•	•	•	
S	38	•	•	•	•	•	•	•

ES-4

3

Assembly preparation

3.1 Lubricate the thread, the cutting ring, the tube end and the taper of the coupling connecting piece and/or of the manual pre-assembly stud lightly (e.g. using mineral-oil based hydraulic fluid HLP32).

Wetting the tube end with lubricant makes it easier to push the ES-4 cutting ring onto the tube.

3.2 Put the union nut and the ES-4 cutting ring on the tube end, one after the other. The cutting edges of the ES-4 cutting ring point towards the tube end.

Attention!

Make sure that the ES-4 cutting ring is in the right position.

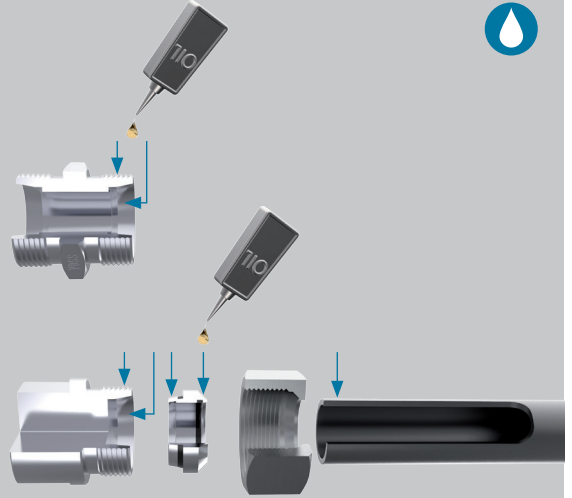

4

Assembly instructions

VOSS ES-4 cutting rings can be pre-assembled directly in the coupling connecting piece or using a hardened pre-assembly die.

Hardened pre-assembly dies are wear-resistant, thus achieving consistent pre-assembly results. They have to be checked after approx. every 50 pre-assemblies for trueness of gauge.

Attention!

Pre-assembly studs that are not true to gauge or that are damaged in the tapered section must be replaced on all accounts. When mounting them directly in the coupling connecting piece, this may be used only once for pre-assembly.

All specified assembly distances must be adhered to. Otherwise there is a danger that the coupling will leak or that the tube will tear out of the coupling.

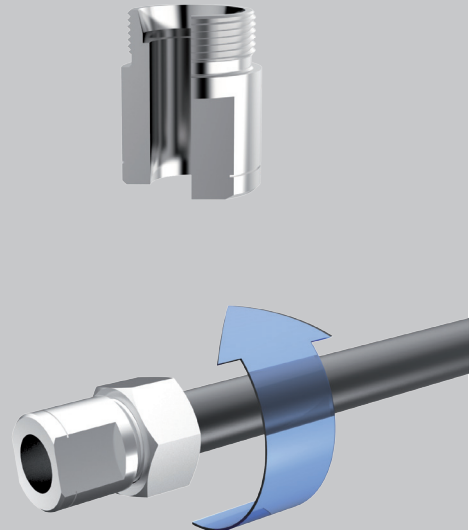

ES-4

4.1 Insert the tube end into the 24° taper as far as it will go and press on it. The tube must be held in as far as it will go during the entire assembly process in order to avoid faulty assembly.

4.2 Turn the union nut until it is hand-tight.

4.3 Tighten the union nut by approx. **1 1/4 turns** (min. 1 to max. 1 1/2 turns). This pushes the ES-4 cutting ring against the end face of the stud.

Notes:

When installing couplings in piping systems, always hold the coupling connecting piece in a spanner. Marking a stroke on the union nut and the tube makes it easier to achieve the correct number of turns.

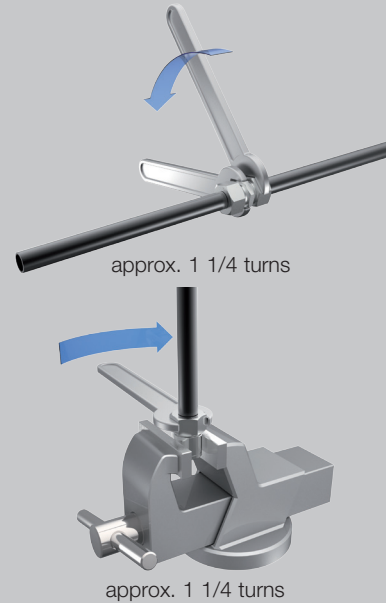

5

Check results

5.1 Loosen the nut and check the shoulder throw-up and the moulded seal. The shoulder throw-up should cover approximate 80 % of the cutting-edge front face.

In this position, it is still permissible for the cutting ring to turn on the tube.

Attention!

The moulded seal must be undamaged. Remove possible soiling and replace the moulded seal if necessary.

If an inadequate amount of material is raised, repeat assembly with a higher torque. The results must be re-checked!

Note:

We recommend the use of the VOSS gauge to check the correct axial position of the cutting ring.

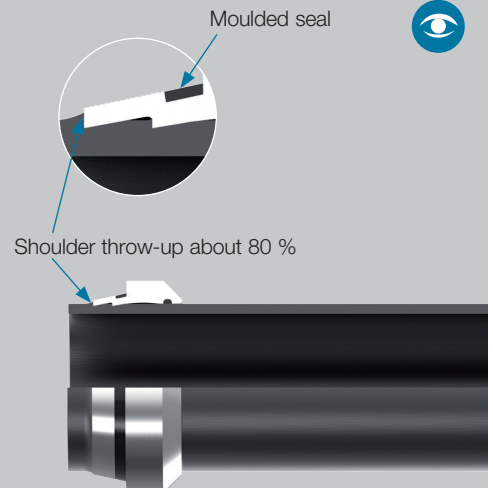

6

Final assembly

6.1 Lubricate the thread, the pre-assembled tube end and the taper of the coupling connecting piece lightly (e.g. using mineral-oil based hydraulic fluid HLP32).

6.2 Insert the pre-assembled tube end carefully into the coupling connecting piece, making sure that the moulded seal is not damaged and is seated in the seal groove correctly. Then turn the union nut until it is hand-tight.

Attention!

If the cutting ring was pre-assembled in the coupling connecting piece, the same coupling connecting piece used to pre-assemble the tube and cutting ring must be used again for final assembly.

6.3 Use a spanner to tighten the union nut until there is a noticeable force increase.

6.4 Tighten up further by approximately **1/4 turns**.

Attention!

When finally tightening up the coupling connecting piece, always hold it in a spanner or clamp it in a vise.



7

Repeat assembly

7.1 Each time the tube coupling is unscrewed, the moulded seal must be checked for damage and replaced if necessary.

7.2 For repeat assembly, the union nut must be tightened again with the same amount of force as during initial assembly.

